

WAHTT 64 LM K

12NC: 859991639550

GTIN (EAN) code: 8003437627620

Whirlpool

SENSING THE DIFFERENCE

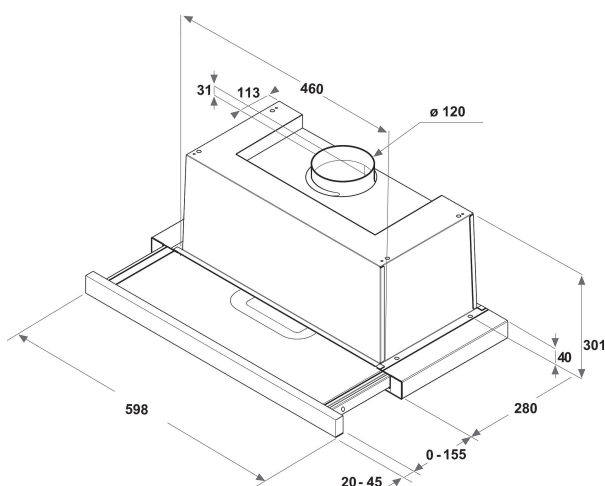

MAIN FEATURES

Product group	абсорбатори
Colour body	Черен
Material body	Stainless steel
Colour chimney	N/A
Material chimney	N/A
Typology	Pull-out
Installation type	Built-in
Type of control	Mechanical
Type of control settings	-
Decor panel options	Possible and included
Motor location	Integrated motor in hood body
Operating Mode	Convertible
Electrical connection rating (W)	181
Current (A)	0,8
Voltage (V)	220-240
Frequency (Hz)	50
Length of Electrical Supply Cord (cm)	150
Plug type	Schuko
Chimney height (mm)	-
Height of product, without chimney (mm)	301
Height of the product	301
Width of the product	300
Depth of the product	600
Minimum niche height	0
Minimum niche width	0
Niche depth	0
Net weight (kg)	9.1

TECHNICAL FEATURES

Type of manual control devices	Buttons
Type of automatic control devices	-
Number of motors	1
Total power of the motors (W)	115
Number of speed settings: boost option availability	3
Boost presence	Yes
Maximum output air extraction (m ³ /h)	581
Boost position air extraction (m ³ /h)	0
Maximum output recirculating air (m ³ /h)	581
Boost position output recirculating (m ³ /h)	0
Light Control Type	On/Off
Number of lights	2
Type of lamps used	LED
Total power of the lamps (W)	6
Diameter of air outlet (mm)	150
No-return airflow flap	Yes
Grease filter material	Washable stainless steel
Odour filter	Yes

ENERGY LABEL

Sound power at min. speed (2010/30/EU)	44
Sound power at max. speed (2010/30/EU)	65
Noise level with boost position (dB(A) re 1 pW)	72